



Aanwijzing Result of RFQ NO: K19390 R01

Day / Date : Thursday, November 13, 2025

Time : 09.00

Venue : Zoom Meeting

Administration:

<p>Before:</p> <ol style="list-style-type: none">Delivery Time:<ul style="list-style-type: none">One set rubber lining for WBM B (half of total quantity) required date maximum November 3, 2025One set rubber lining for WBM A (half of total quantity) required date maximum December 15, 2025Warranty period is 6 months for all item (including bolt, nut, and washer) after installation	<p>After:</p> <ol style="list-style-type: none">Delivery Time:<ul style="list-style-type: none">One set rubber lining for WBM B (half of total quantity) required date maximum December 29, 2025One set rubber lining for WBM A (half of total quantity) required date maximum January 29, 2026Warranty:<ul style="list-style-type: none">Warranty period 8 months for all item (including bolt, nut, and washer also)Warranty will claim if any rubber peeled off for all item based on inspection result. (vendor must supply the warranty item max. 2 weeks after KPJB issued the warranty letter)Warranty counted after material installed.KPJB will send the LOI to start the work, parallel processing the Appointment Letter, Performance Bond and Purchase Order approval.
---	---

Technical:

<p>Before:</p>	<p>After:</p> <ul style="list-style-type: none">We require a vendor that is a specialist in rubber lining, with their own manufacturing workshop and facilities located in Indonesia. (refer TOR point 5.1)1. item no. 1-10 are WBM A&B inside drum rubber lining2. Item No. 11 is WBM A&B inlet chute rubber lining3. Include fastening bolts, nuts, rubber washer seal and cone washer (for item 1-11) * * Material using hot dip galvanize (bolt set quantity total: 400 set or 200/set)
----------------	---



Note:

1. Quotation shall be submitted in two sealed envelopes separately, one for priced quotation and another for unpriced, not later than 11.00 WIB, **November 18, 2025**
2. Mill Certificate of Material, Test, Certificate from Independent Lab (Pusat Penelitian Karet Bogor or Yogyakarta) and Rubber Tensile & Bonding Strength from Internal / Outside Lab (BLK, etc.) or Internal Manufacture Laboratory by Using Calibrated Testing Equipment are required at the delivery time.
3. Delivery Time:
 - One set rubber lining for WBM B (half of total quantity) required date maximum **December 29, 2025**
 - One set rubber lining for WBM A (half of total quantity) required date maximum **January 29, 2026**
4. The others clauses, terms and conditions of this TOR & RFQ No. K19390 R01 that not specified in this MOM of aanwijzing and not against this MOM of aanwijzing still remains unchanged until the parties decided differently.

Attendance List:

NO.	NAME	COMPANY / POSITION	Signature
1	IKHSAN	PT. KPJB	BY ZOOM
2	AZKA	PT. KPJB	BY ZOOM
3	ARTHA	PT. KPJB	BY ZOOM
4	DIAN J	PT. PLN TJB	BY ZOOM
5	JANU	PT. PLN TJB	BY ZOOM
6	ARDIAN	PT. PLN TJB	BY ZOOM
7	YOPI	PT. KARET NGAGEL	BY ZOOM
8	RIVAN	PT. KORABA MANUFAKTUR INDONUSA	BY ZOOM

Attachment:

1. Term of Reference
2. Bidbond Format
3. DPJT List Bank

	PT. KOMIPO PEMBANGKITAN JAWA BALI PLTU TANJUNG JATI B UNIT 3&4	Doc. Ref	: KPJB-0951-02
		Form No.	: KPJB-0951-02-ZZ-FM-16
	TERM OF REFERENCE	Design Div.	: Finance and Administration
		Revision No.	: 00

1. Background

The spare parts will be provided to equipment as follow:

Name : Wet Ball Mill A&B Rubber Lining (half side)

Brand : -

2. Spare Part Data

2.1. System : Reagent Preparation

Equipment : Wet Ball Mill A&B

2.2. Spare Part Group :

Overhaul

PM &PdM

Run to Failure

Strategic Parts

Strategic Equipment

2.3. Usage Plan :PARTS WILL BE INSTALLED :

1. WBM B rubber lining replacement scheduled in November 2025

2. WBM A rubber lining replacement scheduled in December 2025

2.4. Description :

NO	DESCRIPTION	Item ID	QTY	UNIT	MANUFACTURE
1	LINING, FRICTION, LIFTER BAR WET BALL MILL SBC 220 x 450, LENGTH: 1353	202138	32	PC	-
2	LINING, FRICTION, SHELL LINER WET BALL MILL, LENGTH: 1353 MM	206474	32	PC	-
3	LINING, FRICTION, LIFTER BAR INLET CONE WET BALL MILL	206477	24	PC	-
4	LINING, FRICTION, SHELL LINER INLET CONE WET BALL MILL	206476	24	PC	-
5	LINING, FRICTION, OUTER RING (CORNER) INLET CONE WET BALL MILL	206478	2	SET	-
6	LINING, FRICTION, INNER RING INLET SEAL CONE WET BALL MILL	206479	2	SET	-
7	LINING, FRICTION, SHELL LINER REAR MAHOLE WET BALL MILL	206480	2	PC	-
8	LINING, FRICTION, SHELL LINER FRONT MAHOLE WET BALL MILL	206481	2	SET	-
9	LINING, FRICTION, SEAL FOR INLET CHUTE WET BALL MILL, THICKNESS : 10 MM, OUTSIDE DIA. : 485 MM , INSIDE DIA. : 305 MM, HARDNESS : 30-35 SHORE A	206483	2	PC	-
10	LINING, FRICTION, MANHOLE LINER WET BALL MILL	206484	4	PC	-
11	RUBBER BAND, RUBBER LINING FOR INLET CONE INSIDE DRUM OF WET BALL MILL, OUT DIA.: 850MM, IN DIA.: 350MM, HEIGHT : 600MM, MATERIAL RUBBER, THICKNESS : 8MM, HARDNESS 70±5 SHORE A, ABR RST DIN 30-40MM3	216221	2	PC	-

Note:

1. Item no 1-10 are WBM A&B inside drum rubber lining

2. Item no. 11 is WBM A&B inlet chute rubber lining

3. Include fastening bolts, nuts, rubber washer seal and cone washer (for item 1-11)*

*material using hot dip galvanize (bolt set quantity total: 400 set or 200 per set)

3. Work Scope

Purchase rubber lining spareparts for Limestone Wet Ball Mill A&B rubber lining

4. CSMS level is Low

5. Bidder Qualification

5.1. Rubber lining specialist vendor (Have workshop and manufacture from indonesia)

6. Delivery of material and/or services

6.1. One set rubber lining for WBM B (half of total quantity in description point 2.4)
Required date **03 November 2025** (The delivery before 24 October 2025 is prohibited)

	PT. KOMIPO PEMBANGKITAN JAWA BALI PLTU TANJUNG JATI B UNIT 3&4	Doc. Ref	: KPJB-0951-02
		Form No.	: KPJB-0951-02-ZZ-FM-16
	TERM OF REFERENCE	Design Div.	: Finance and Administration
		Revision No.	: 00

- 6.2. One set rubber lining for WBM A (half of total quantity in description point 2.4) Required date is **01 December 2025** (The delivery before 24 November 2025 is prohibited)
- 6.3. Requirement document (TOR Point 7) must be submitted in the first sparepart delivery
- 6.4. For item no.7,8 and 11 (in description point 2.4) , The winner vendor can bring inlet chute and manhole plate from KPJB to the winner vendor workshop base on user schedule
- 6.5. Delivery point is KPJB's Warehouse, PLTU Tanjung Jati B Unit 3&4, Jepara, Central Java.

7. Requirement of Documents

Within delivery the materials, supplier should submit documents as follow:

- 7.1. Mill certificate of materials
- 7.2. Certificate of testing from independent laboratory (Pusat Penelitian Karet from Bogor) or (Balai Penelitian Karet from Yogyakarta).
- 7.3. Rubber tensile and bonding strenght from internal laboratory or from outside laboratory (BLK, etc) or internal manufacture labotratory by using calibrated testing equipment.
- 7.4. Warranty letter from Supplier.

8. Technical Specification

- 8.1. All of technical specification should be comply with determined specification, cannot be changed, no crack, should be new 100%, genuine, no defect, and can be used properly.
- 8.2. In the case PT KPJB decline the delivered material, supplier should replace the material. If supplier can't replace it, they will be penalized in accordance to General Term & Condition (GTC) of the PO.
- 8.3. Wet Ball Mill A&B inside drum rubber lining spesification:
 - a. Shell liner & lifter bar

Properties	Test Method	Specification
Compound		High grade natural rubber
Hardness (shore A)	ASTM D.2240-05	65±5
Tensile strength (Mpa)	ASTM D.412-06ae2	18 (min)
Elongation at break (%)	ASTM D.412-06ae2	450 (min)
Specific gravity, g/cm ³	ASTM D.297-02	1.100 (min)
Abrasion resistance, mm ³	ASTM D.5963-04	50 (max)
Rebound resilience (LUPKE), %	ISO 4662:2009(E)	45 (min)
Bonding strength between frame and rubber	Tensile test	33 kg/cm2 (min)

- 8.4. For item no.7&8, KPJB provide manhole plate to the winner vendor for install the rubber lining shell and lifter bar.



Manhole plate



Rubber lining installation

	PT. KOMIPO PEMBANGKITAN JAWA BALI PLTU TANJUNG JATI B UNIT 3&4	Doc. Ref	: KPJB-0951-02
		Form No.	: KPJB-0951-02-ZZ-FM-16
	TERM OF REFERENCE	Design Div.	: Finance and Administration
		Revision No.	: 00

8.5. For item no.11, the winner vendor conducted rubber lining and chute recondition (repair chute by welding/pad by plate lining if any leakage /eroded plate at inlet chute).

Lining method are using single or double layer rubber sheet with minimum thickness is 8 mm

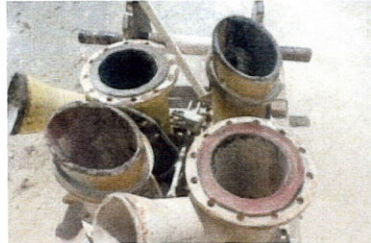

Inlet chute position



eroded plate at inlet chute



8.6. Supervise from the winner vendor for rubber lining installation.

8.7. Allowance for all item variation of tolerance (lifter bar, shell plate & head plate) are +2mm and -1mm.

8.8. Full backing plate for product not only welding tack intermittent.

8.9. **Measuring for every item (after production) and check stock witness by KPJB & PLN.**

8.10. The winner vendor or participant can measure existing rubber lining before production started.

9. Acceptance Criteria

9.1. Delivery time is complied.

9.2. All delivered materials are accordance to PO requirement, specification and condition of the TOR.

9.3. All of required document are fulfilled.

10. Standard of Quality

Quality of the material and/or services should comply with standard, code, manufacturer specification and user's requirement. (or determined by user)

11. Warranty

11.1. Warranty counted after materials installed

11.2. We will claim if any rubber peeled off for all items based on inspection result. (the vendor must supply the warranty item max. 2 weeks after KPJB issued the warranty letter)

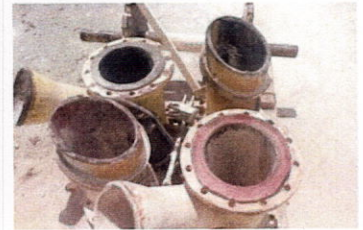
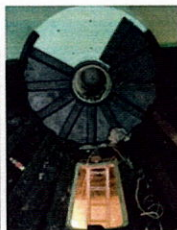

11.3. Warranty period is 6 month for all item (including bolt, nut and washer also)

Picture



WBM inside drum rubber lining

Inlet chute cone

Sign		
	Staff	Manager



	PT. KOMIPO PEMBANGKITAN JAWA BALI PLTU TANJUNG JATI B UNIT 3&4	Doc. Ref	: KPJB-0951-02
		Form No.	: KPJB-0951-02-ZZ-FM-16
	TERM OF REFERENCE	Design Div.	: Finance and Administration
		Revision No.	: 00

11. Drawing

Details in attachment

12. Others

Aaweijing required

Prepared by	Checked by	Approved by
		
<u>Artha B.N</u>	<u>Hermawan</u>	<u>Lim Hyung Chul</u>
Date :	Date : 16 June '25	Date :

	PT. KOMIPO PEMBANGKITAN JAWA BALI PLTU TANJUNG JATI B UNIT 3&4	Doc. Ref	: KPJB-0951-02
		Form No.	: KPJB-0951-02-ZZ-FM-16
	TERM OF REFERENCE	Design Div.	: Finance and Administration
		Revision No.	: 00

Attachment

	PT. KOMIPO PEMBANGKITAN JAWA BALI PLTU TANJUNG JATI B UNIT 3&4	Doc. Ref	: KPJB-0951-02
		Form No.	: KPJB-0951-02-ZZ-FM-16
	TERM OF REFERENCE	Design Div.	: Finance and Administration
		Revision No.	: 00

- WBM A&B rubber lining



Rubber lining based on item and quantity

- WBM rubber lining replacement

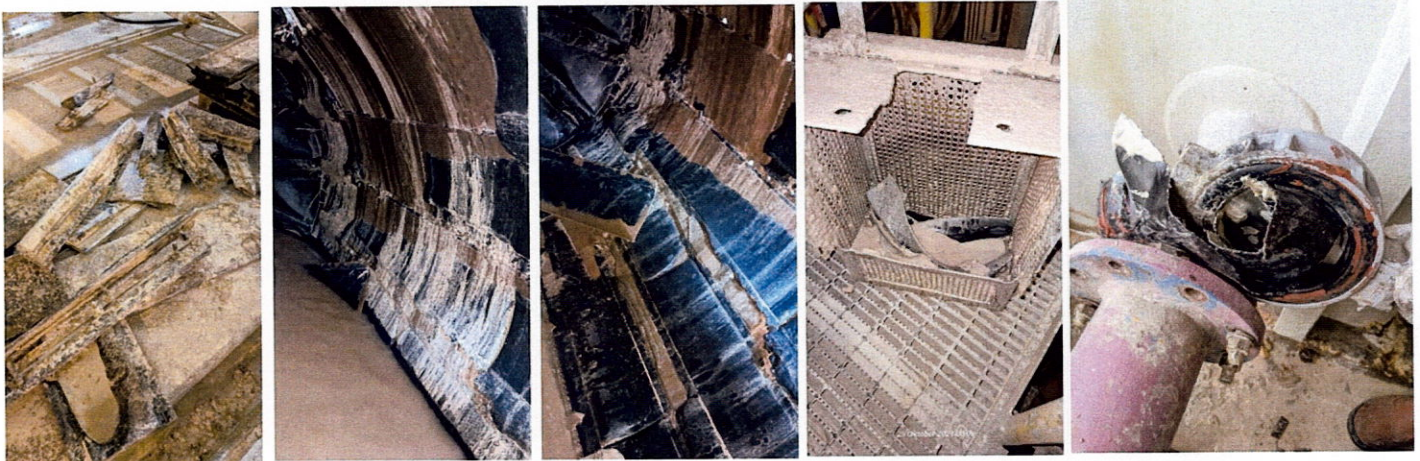

Existing rubber lining condition
(after 6 – 7 month operating)

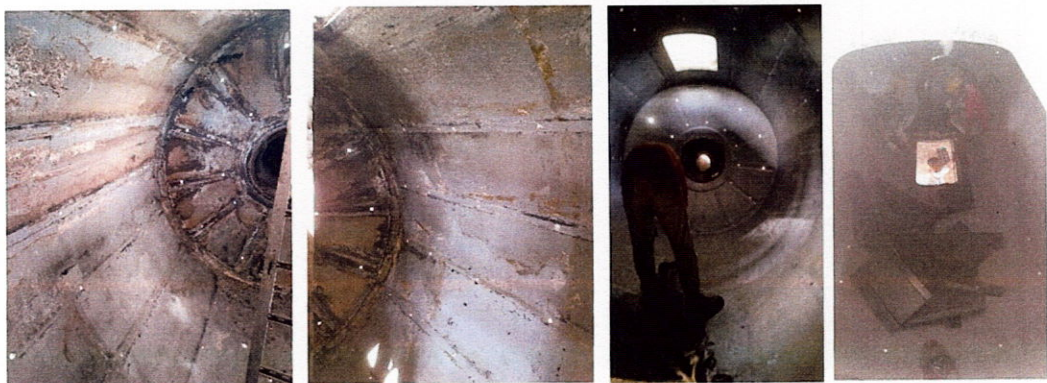

Cleaning & painting inside drum

	PT. KOMIPO PEMBANGKITAN JAWA BALI PLTU TANJUNG JATI B UNIT 3&4	Doc. Ref	: KPJB-0951-02
		Form No.	: KPJB-0951-02-ZZ-FM-16
	TERM OF REFERENCE	Design Div.	: Finance and Administration
		Revision No.	: 00



Install new rubber lining

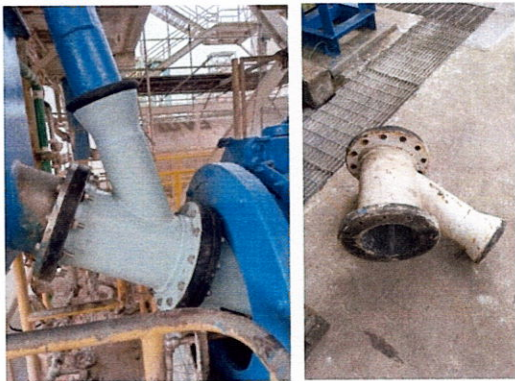

Replace existing inlet chute with repaired chute (re lining & re welding chute)



Fabricating and install manhole

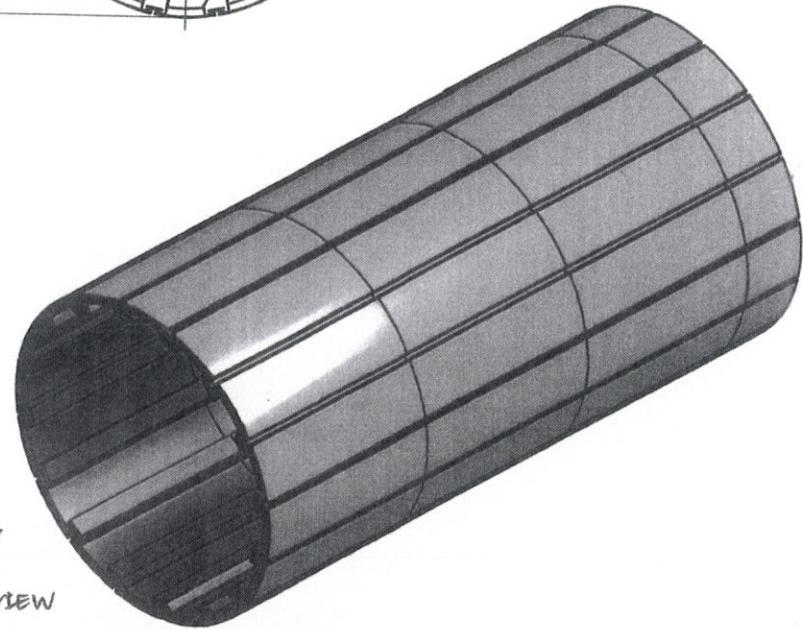
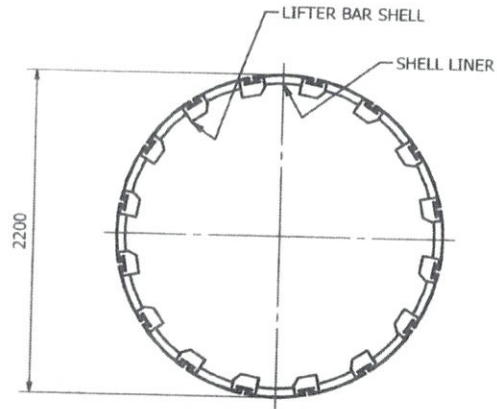
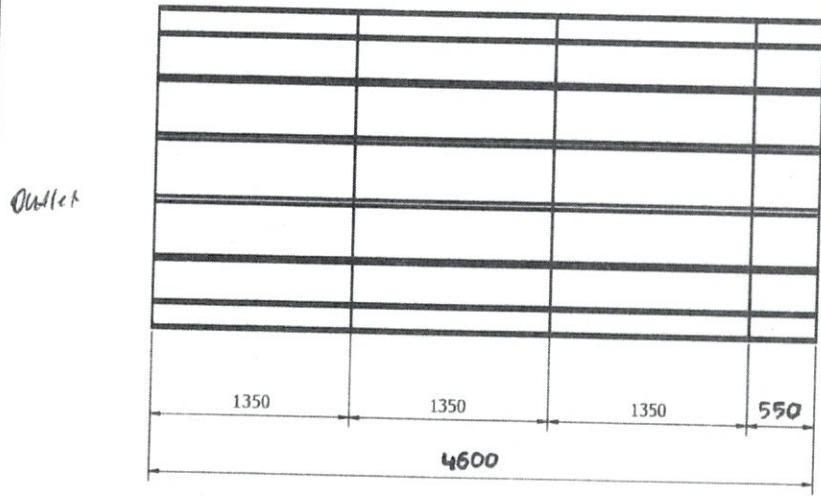

INLET →
SHELL LINER VIEW

Designed by	Checked by	Approved by	Date	Date
IM				11/24/2013
1/8 <i>Ar</i>			ARRANGEMENT & DETAIL SHELL LINER BALL MILL	
KN-13054-SHL			Edition	Sheet
				1 / 2

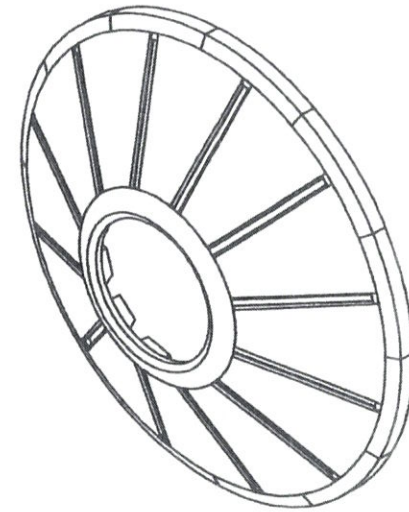
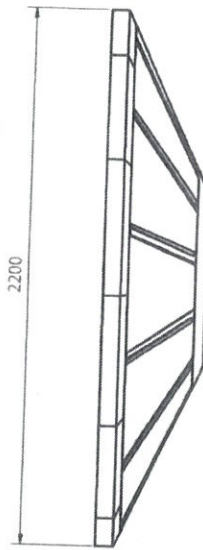
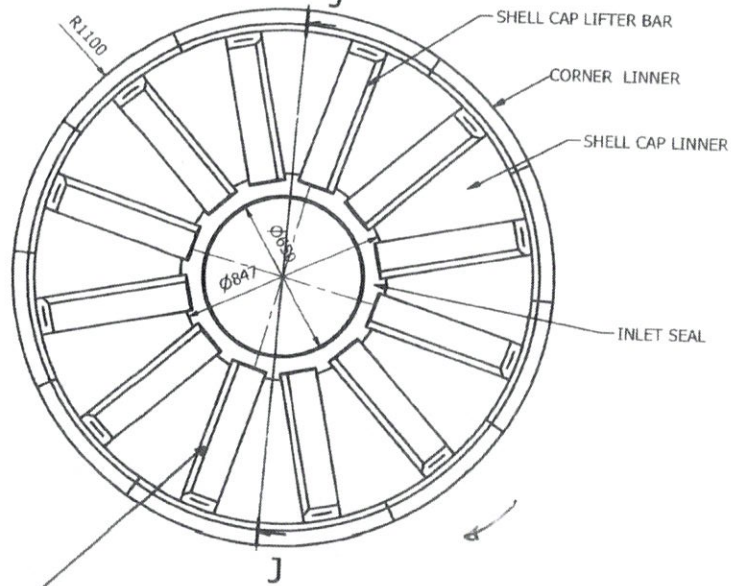

CAP SHELL LAYOUT

NOTE :

FOR LIFTER BAR SHELL CAP
INLET & OUTLET ARE REVERSE ANGEL /
OPPOSITE ANGEL .

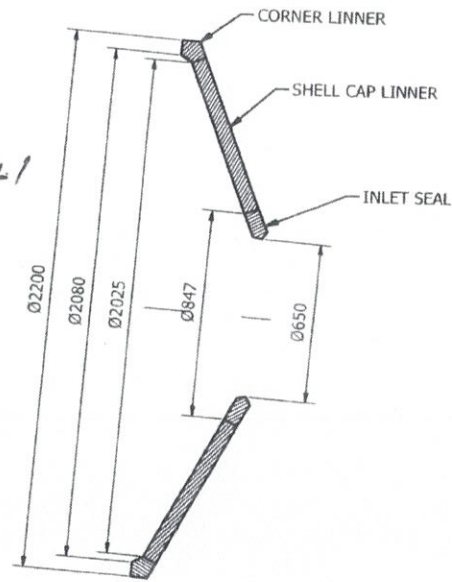

SECTION J-J

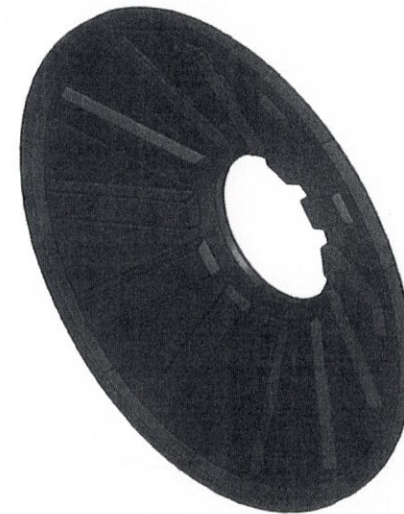

Designed by IM	Checked by	Approved by	Date	Date 11/24/2013
2/B <i>[Signature]</i>			ARRANGEMENT & DETAIL SHELL CAP LINNER BALL MILL	
			KN-13054-CPL	Edition Sheet 1 / 2

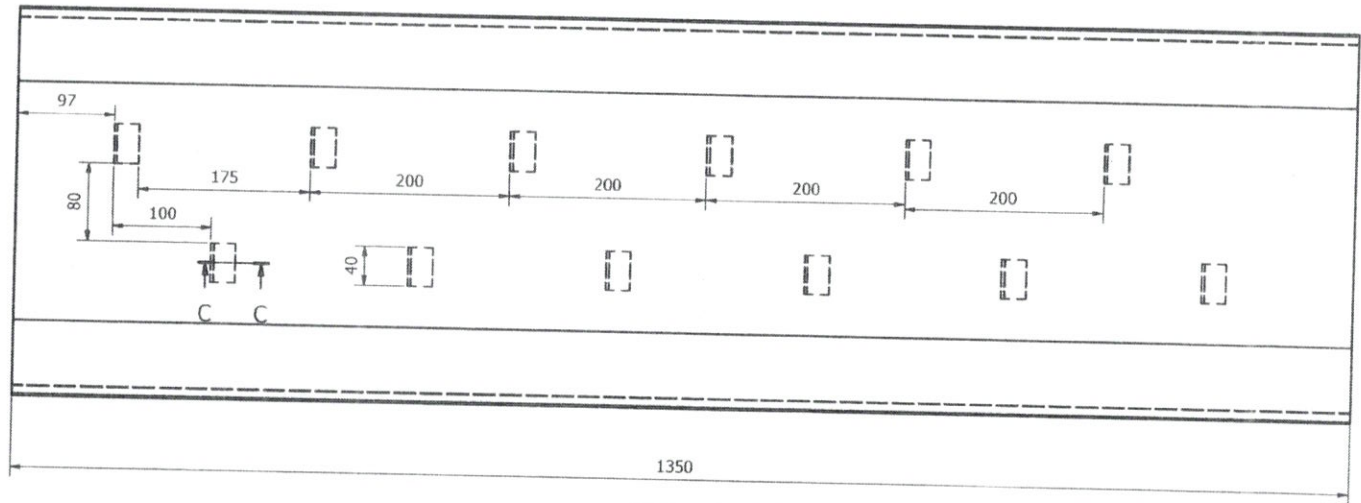
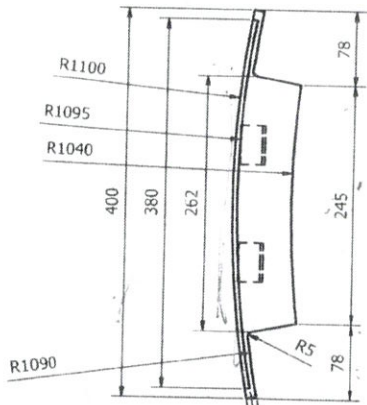

SHELL LINNER

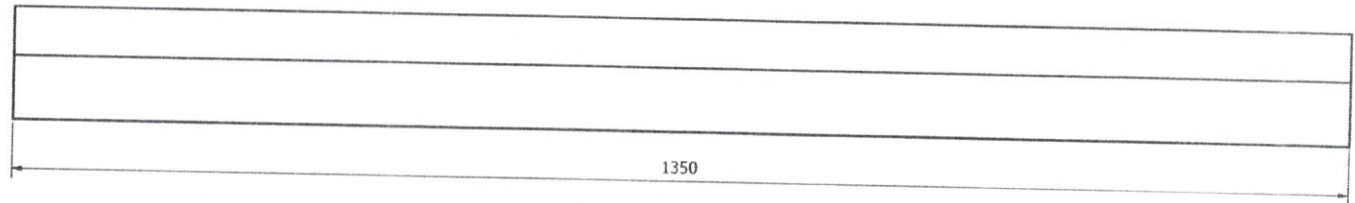
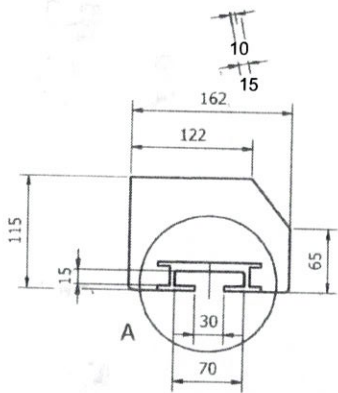

LIFTER BAR SHELL

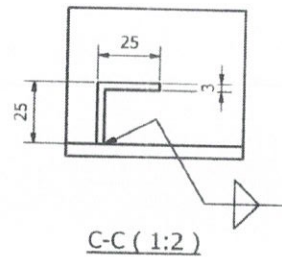
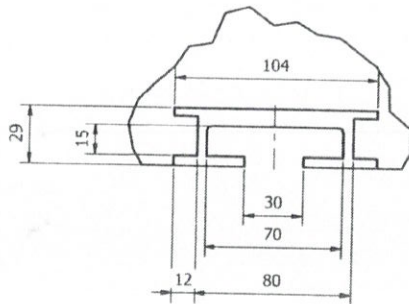

Designed by IM	Checked by	Approved by	Date	Date 11/24/2013
3/18/13			ARRANGEMENT & DETAIL SHELL LINER BALL MILL	
KN-13054-SHL			Edition	Sheet 2 / 2

OK

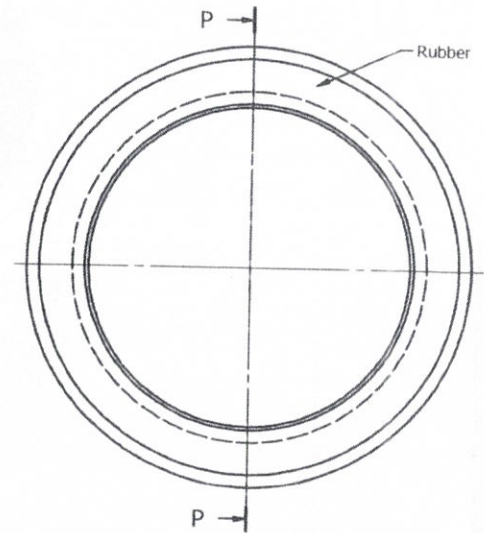
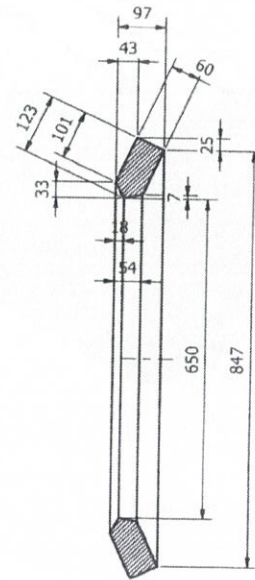
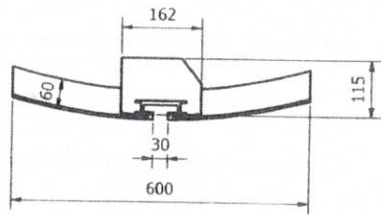
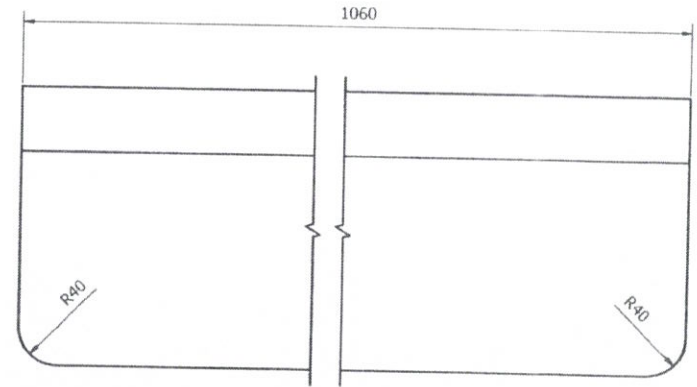
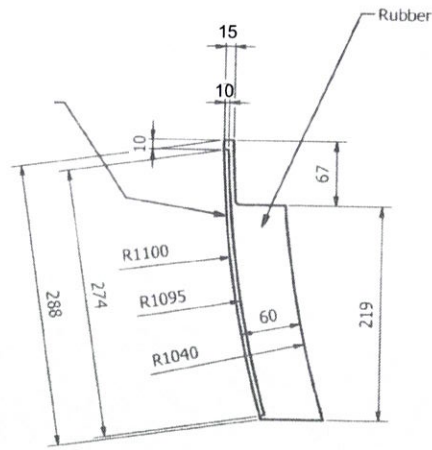
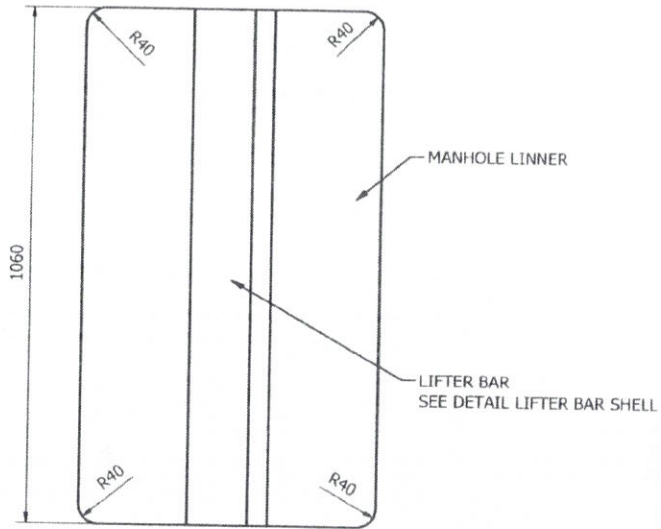

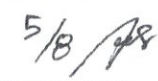
Designed by IM	Checked by	Approved by	Date	Date 11/24/2013
			MANHOLE LINER & INLET SEAL DETAIL BALL MILL	
			KN-13054-MH	Edition Sheet 1 / 1

ORIGINAL . OK.

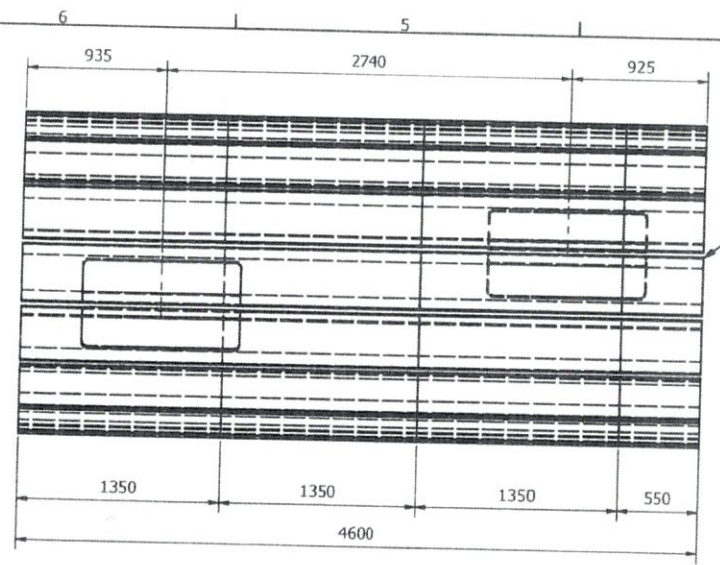

LIFTER BAR OMITTED FOR CLARIFICATION

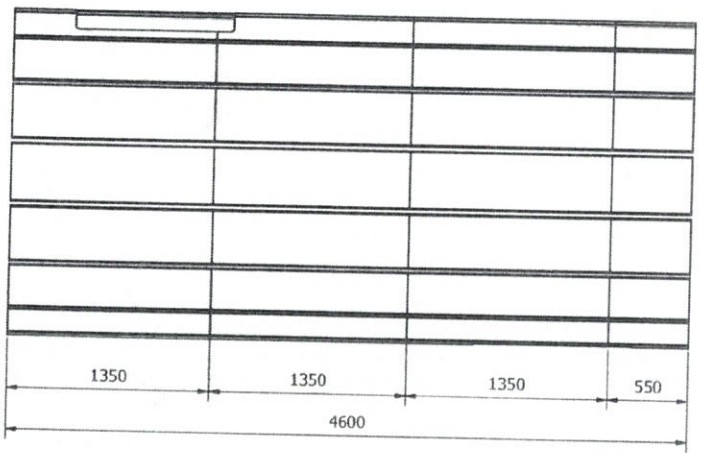

SHELL LINNER & MANHOLE LINER ARRANGEMENT

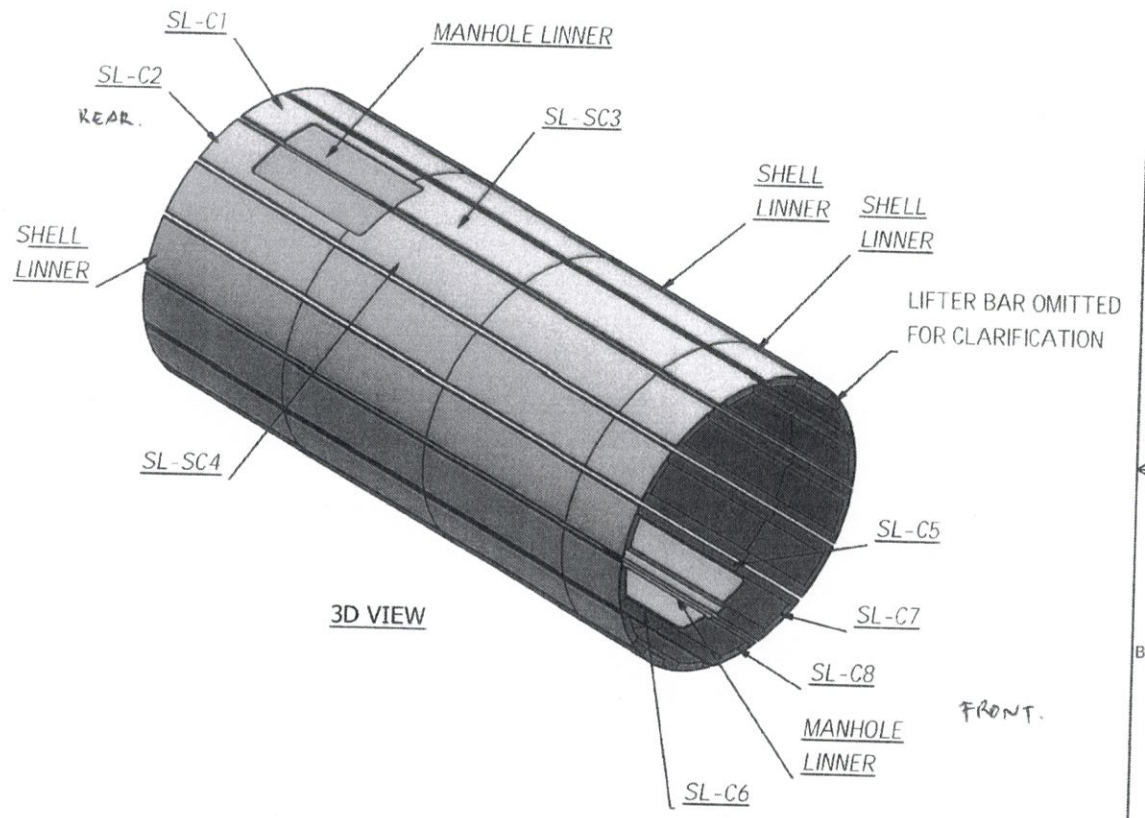

3D VIEW

check at "Inube" Stage - 18/2/14.

Designed by IM	Checked by	Approved by	Date	Date 2/6/2014
6/8/14			SHELL LINNER & MANHOLE LINER	
			KN-13054-SML	Sheet 1 / 3

ORIGINAL OK

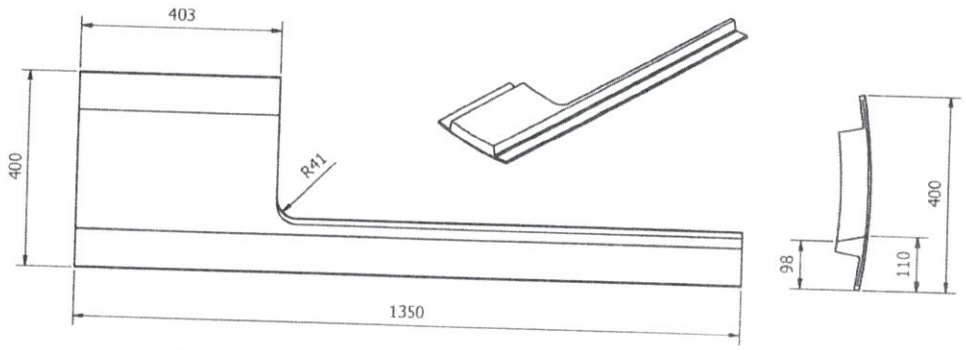
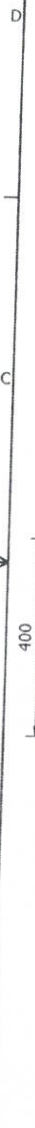
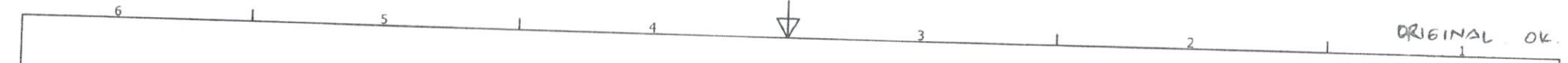

SHELL LINNER SL-C1

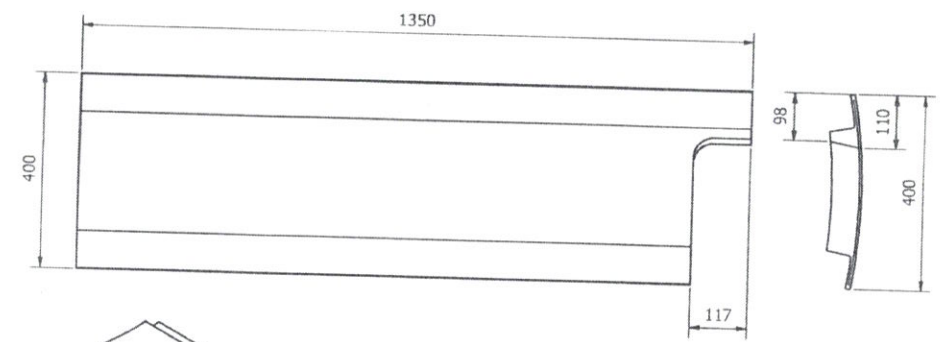

SHELL LINNER SL-C3

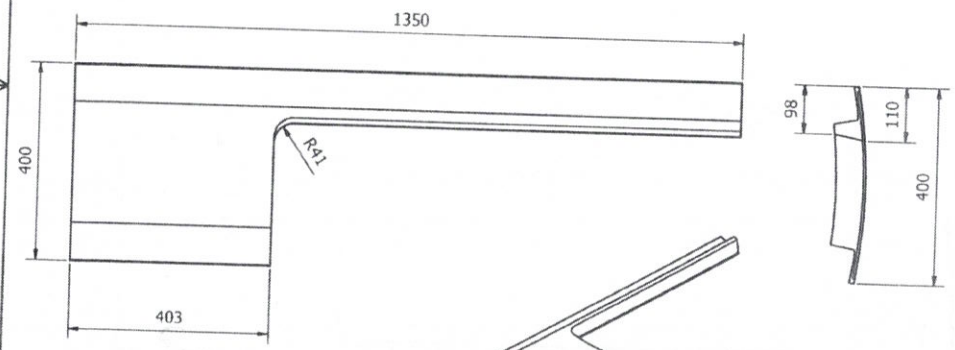

SHELL LINNER SL-C2

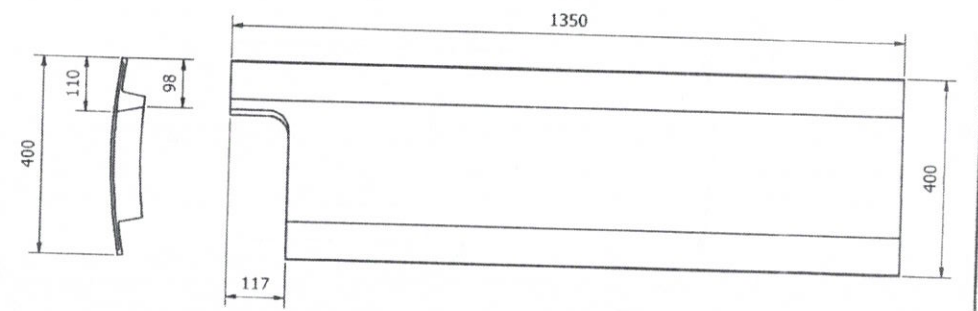

SHELL LINNER SL-C4

Check at Inhaber Sby. 18/2/14

REAR MANHOLE

Designed by IM	Checked by	Approved by	Date	Date 2/6/2014
7/8/14			SHELL LINNER & MANHOLE LINER	
KN-13054-SML			Edition	Sheet 2 / 3



ORIGINAL. OK.

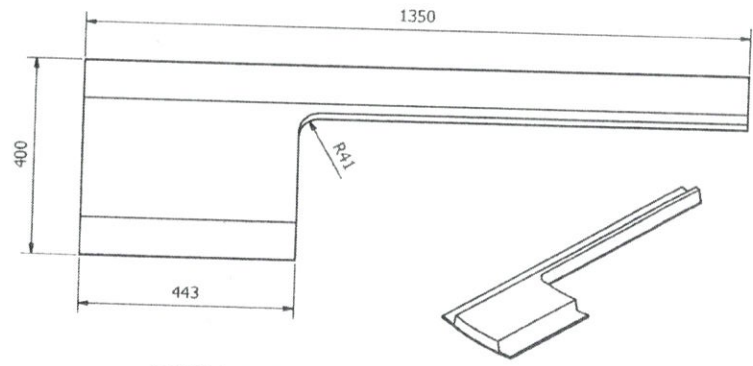

SHELL LINNER SL-C5

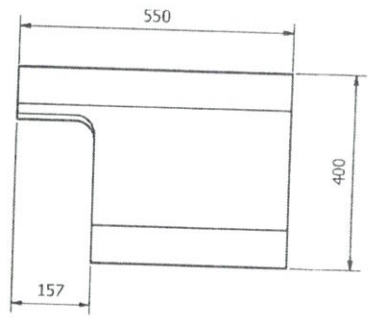
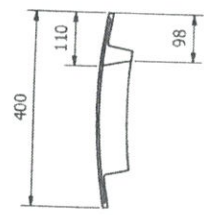
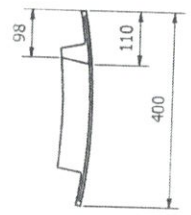

SHELL LINNER SL-C7

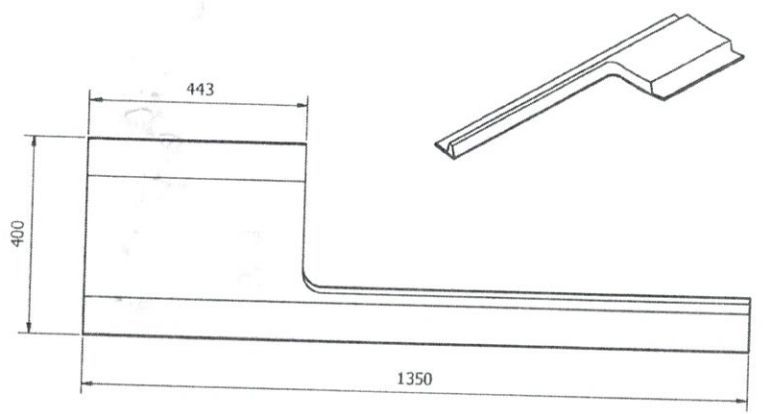
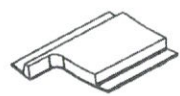

SHELL LINNER SL-C6

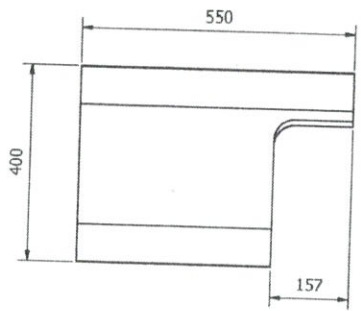
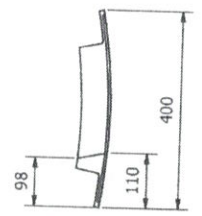

SHELL LINNER SL-C8

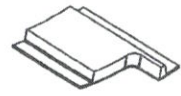
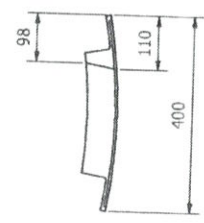

check at "Inaber" Strg.
18/2 '14.

FRONT. MANHOLE

Designed by IM	Checked by	Approved by	Date	Date 2/6/2014
			SHELL LINNER & MANHOLE LINER	
			KN-13054-SML	Sheet 3 / 3

**INFORMASI DAFTAR PENERBIT JAMINAN TERSELEKSI
PENGADAAN BARANG/JASA DI LINGKUNGAN PT PLN (PERSERO)**

KLASIFIKASI	BATASAN NILAI KONTRAK	PENERBIT JAMINAN	BERLAKU SAMPAI DENGAN
I	TIDAK ADA BATASAN NILAI KONTRAK	PT BANK RAKYAT INDONESIA (PERSERO) TBK.	15 Desember 2024
		PT BANK MANDIRI (PERSERO) TBK.	15 Desember 2024
		PT BANK NEGARA INDONESIA (PERSERO) TBK.	15 Desember 2024
		PT BANK CENTRAL ASIA TBK.	15 Desember 2024
		PT BANK DANAMON INDONESIA TBK.	15 Desember 2024
		PT BANK CIMB NIAGA TBK.	15 Desember 2024
		LEMBAGA PEMBIAYAAN EKSPOR INDONESIA	15 Desember 2024
		PT BANK TABUNGAN NEGARA (PERSERO) TBK.	15 Desember 2024
		BANK OF CHINA (HONGKONG) LTD CABANG JAKARTA	15 Desember 2024
II	NILAI KONTRAK ~ Rp 1 TRILIUN	MUFG BANK LTD	15 Desember 2024
		PT BANK OCBC NISP TBK.	15 Desember 2024
		PT BANK PERMATA TBK.	15 Desember 2024
		PT BANK UOB INDONESIA	15 Desember 2024
		PT BANK KB BUKOPIN TBK.	15 Desember 2024
		PT BANK SYARIAH INDONESIA TBK.	15 Desember 2024
		PT BANK MAYBANK INDONESIA TBK.	15 Desember 2024
		PT BPD JAWA TIMUR TBK.	15 Desember 2024
		PT BANK BTPN TBK.	15 Desember 2024
III	NILAI KONTRAK ~ Rp 150 MILIAR	PT BANK MIZUHO INDONESIA	15 Desember 2024
		PT BANK ICBC INDONESIA	15 Desember 2024

Jakarta, 30 Agustus 2024
PT PLN (PERSERO)
DIREKTUR KEUANGAN

SINTHYA ROESLY

**BANK GUARANTEE
BID BOND UNDER SE BI**
_____ [number]
_____ [places & dated]

To :

**PT. Perusahaan Listrik Negara (Persero) UIK
Tanjung Jati B**
Desa Tubanan, Kecamatan Kembang, Kabupaten Jepara
Jawa Tengah, 59457

Whereas PT Bank _____ [name of bank] domiciled in and having its address at _____ [address] (hereinafter referred to as the “Bank”), hereby irrevocably guarantee _____ [name of applicant] having a registered address at _____ [address] (hereinafter refer as the “Principal”) for the favour of PT.

Perusahaan Listrik Negara (Persero) UIK Tanjung Jati B having a registered office at _____ (hereinafter refer as the “Beneficiary” to make a payment of amount up to _____ (say: _____) if the Principal has failed and/or neglected to perform its obligation, including if Principal does not follow the procurement process and/or does not sign/enter into contracts/agreements or fulfill other provisions as specified in the Bid Document _____ no _____ date _____ [Bid Document] (“Bid Document”) for the Project of _____ [name of Project], including but not limited to the Principal failure to maintain the validity period of this Bank Guarantee in accordance with the Bid Document and/or request of the Beneficiary.

This Bank Guarantee is issued with the following provisions:

1. This Bank Guarantee shall be effective on and as of the date of _____ until _____ [maturity date].
2. The payment of Bank Guarantee shall be made without require Principal approval upon our receipt of Beneficiary’s first written demand

**BANK GARANSI
JAMINAN PENAWARAN BERDASARKAN
SE BI**

_____ (Nomor)
_____ (Tempat & Tanggal)

Kepada :

**PT. Perusahaan Listrik Negara (Persero) UIK
Tanjung Jati B**
Desa Tubanan, Kecamatan Kembang, Kabupaten Jepara
Jawa Tengah, 59457

PT Bank _____ [nama bank] berkedudukan di _____ [alamat], (untuk selanjutnya disebut “Bank”), dengan ini menjamin tanpa dapat ditarik kembali _____ [nama badan usaha penyedia barang/jasa] beralamat di _____ (untuk selanjutnya disebut “Terjamin”) terhadap PT. Perusahaan Listrik Negara (Persero) UIK Tanjung Jati B beralamat di _____ (untuk selanjutnya disebut sebagai “Penerima Jaminan”), untuk membayar sejumlah uang sebesar _____ (terbilang: _____) apabila Terjamin melakukan tindakan dan/atau gagal untuk melakukan tindakan termasuk apabila Terjamin tidak mengikuti proses pengadaan dan/atau tidak menandatangani/memasuki kontrak/perjanjian atau memenuhi ketentuan lainnya sebagaimana ditentukan dalam Dokumen Pengadaan _____ no _____ tanggal _____ [Dokumen Pengadaan] (“Dokumen Pengadaan”) untuk _____ [nama proyek], termasuk namun tidak terbatas pada kegagalan Terjamin untuk memelihara masa berlaku Bank Garansi ini sesuai Dokumen Pengadaan dan/atau permintaan Penerima Jaminan.

Bank Garansi ini dikeluarkan dengan ketentuan-ketentuan sebagai berikut:

1. Bank Garansi ini berlaku efektif sejak tanggal _____ dan akan berakhir pada tanggal _____ [tanggal jatuh tempo].
2. Pembayaran atas Bank Garansi ini dilakukan tanpa perlu mendapat persetujuan Terjamin setelah adanya

- stating that the Principal has failed to fulfill its obligation under the Contract and the amount to be paid to Beneficiary by attaching of the original of this Bank Guarantee.*
3. *The deadline for submission and receipt of any claim on this Bank Guarantee by Beneficiary to the Bank shall be made in writing, not later than 30 (thirty) calendar days from the date of maturity of this Bank Guarantee, provided that if the date falls on holiday or a day on which banking institutions are permitted to be closed, then the submission shall be made no later than one working day thereafter.*
 4. *The Bank shall be firmly bound unto the Beneficiary for the Payment in the amount as mention above not later than 15 (fifteen) calendar days after receipt of Beneficiary's first written demand and the original of Bank Guarantee to the Bank.*
 5. *With reference to Article 1832 of Indonesian Civil Code (Kitab Undang-Undang Hukum Perdata), the Bank hereby relinquish/waives its privileges/rights granted by law to claim/demand on asset belonging to the Principal and/or bound as collateral be confiscated, seized or sold in advance for the discharge of Principal debts as stipulated under Article 1831 of Indonesian Civil Code.*
 6. *The payment of Bank Guarantee claims/demands is absolute and unconditional even though there is a demand, request or objection from the principal or any other party whatsoever.*
 7. *The payment of bank Guarantee claims/demand will be made to the account designated by the Beneficiary, free and clear of, without any reduction for any reason, either present or future, of all taxes, levies, fees or withholding whatsoever, imposed or collected with respect thereto.*
- surat permintaan pencairan Bank Garansi dari Penerima Jaminan kepada Bank yang menyatakan bahwa Terjamin wanprestasi/gagal memenuhi kewajibannya berdasarkan Kontrak dan jumlah yang harus dibayarkan kepada Penerima Jaminan beserta asli Bank Garansi ini.
3. Batas waktu pengajuan dan penerimaan tuntutan penagihan/klaim atas Bank Garansi ini adalah selambat-lambatnya 30 (tiga puluh) hari kalender sejak tanggal jatuh tempo Bank Garansi ini, dengan ketentuan apabila tanggal tersebut jatuh pada hari libur atau diluar hari kerja Bank, maka pengajuan akan dilakukan selambat-lambatnya pada satu hari kerja Bank setelahnya.
 4. Bank akan membayar kepada Penerima Jaminan untuk jumlah tersebut di atas seketika selambat-lambatnya 15 (lima belas) hari kalender setelah diterimanya surat permintaan pencairan Bank Garansi dan Asli Bank Garansi dari Penerima Jaminan kepada Bank.
 5. Dengan mengacu pada Pasal 1832 Kitab Undang-Undang Hukum Perdata, Bank dengan ini melepaskan hak-hak istimewa yang diberikan oleh undang-undang sebagaimana dimaksud dalam Pasal 1831 Kitab Undang-Undang Hukum Perdata untuk menuntut supaya benda-benda milik Terjamin dan/atau yang diikat sebagai jaminan lebih dahulu disita dan dijual untuk melunasi hutang Terjamin.
 6. Pembayaran atas klaim/tuntutan pencairan adalah mutlak dan tanpa syarat (*unconditional*) meskipun ada tuntutan, permintaan atau keberatan dari Terjamin atau pihak manapun.
 7. Pembayaran atas klaim/tuntutan pencairan Bank Garansi akan dilakukan ke rekening

8. *This Bank Guarantee is non-transferable and/or cannot be pledged to another party*
9. *This Bank guarantee can't be amended, modified or supplement unless such amendment, modification or supplemented has been approved by Beneficiary in written or as expressly required by Beneficiary to Applicant.*
10. *This Bank Guarantee shall be governed by and construed in accordance with laws and regulations applicable in Indonesia.*
11. *For the purpose of this Bank Guarantee issuance and any consequence thereof, Bank chooses the Court of _____ [domicile of court] as general and permanent domicile.*
12. *This Bank Guarantee has been executed in both Bahasa Indonesia and English. The two versions of this Bank Guarantee shall not be construed as separate documents and, when taken together, shall constitute one and the same instrument. In the event of any conflict or inconsistency between the English language version and the Bahasa Indonesia language version of Bank Guarantee.*

This Bank Guarantee is issued by duly authorized officers on the date _____ and to be used by properly interested party

_____ [places/tempat], _____ [dated/tanggal]

PT _____ [name of bank/nama bank]

[Bank Stamp/Cap Bank]

_____ [authorized signatory/tandatangan pejabat yang berwenang]

bank yang ditunjuk oleh Penerima Jaminan, bebas dan bersih serta tanpa pengurangan dengan alasan apapun, baik yang berlaku pada saat ini atau kemudian, dari semua pajak, pungutan, biaya atau pemotongan apapun, yang dibebankan atau dipotong sehubungan dengan hal-hal tersebut.

8. Bank Garansi ini tidak dapat dipindahtangankan dan/atau dijaminan kepada pihak lain (*non-transferable*).
9. Bank Garansi ini tidak dapat diubah kecuali perubahan tersebut disetujui oleh Penerima Jaminan melalui surat tertulis atau secara tegas dimintakan oleh Penerima Jaminan kepada Terjamin.
10. Bank Garansi ini diatur oleh dan ditafsirkan berdasarkan peraturan perundang-undangan yang berlaku di Indonesia.
11. Untuk tujuan Bank Garansi ini dengan segala akibat hukumnya, Bank memilih domisili yang tetap di Kantor Panitera Pengadilan Negeri di _____ [domisili pengadilan].
12. Bank Garansi ini dibuat dalam Bahasa Indonesia dan Bahasa Inggris. Dua versi dari Bank Garansi ini tidak dapat ditafsirkan sebagai dokumen terpisah, dan ketika ditandatangani bersama, harus dianggap satu dan merupakan instrumen yang sama. Dalam hal terdapat konflik atau ketidaksesuaian antara versi Bahasa Inggris dan versi Bahasa Indonesia atas Bank Garansi ini, maka versi Bahasa Indonesia akan berlaku.

Demikian Bank Garansi ini di terbitkan oleh yang berwenang pada tanggal _____ untuk dapat dipergunakan sebagaimana mestinya dan oleh yang berkepentingan.